



WIDESPREAD METERING

Z867B0

TAG _____



Engineering Specifications: Zurn AquaSpec® Z867B0

Polished chrome-plated 8" [203mm] widespread faucet with a 5-3/8" [137mm] centerline rigid or swing gooseneck spout, slow-closing metering cartridges, and vandal-resistant ADA compliant color-coded metal handles. Easily adjustable cycle time, preset to 10 seconds at 80 PSI. Unit is furnished with a water-conserving aerator which reduces flow to .25 GPC [.95 L] (complying with ANSI A112.18.1 Standard for flow), mounting hardware, 1/2" NPSM coupling nuts for standard lavatory risers and integral shank filters.

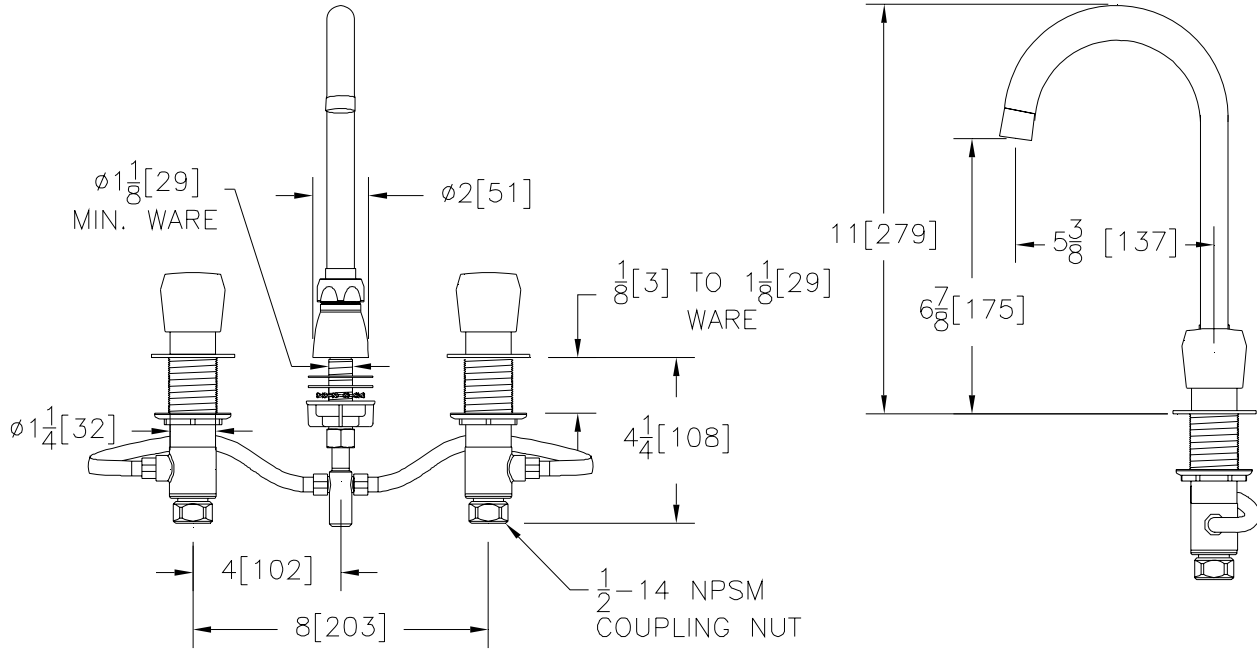

Note: All dimensions are for reference only. Do not use for pre-plumbing



OPTIONAL ACCESSORIES

Suffix	Description
___-CWO	Cold Water Only
___-G	1-1/4" [32mm] Grid Strainer Drain
___-GH	1-1/4" [32mm] Offset Handicap Drain
___-ICT	Inter-connecting Copper Supply Tubes for 8" In-line Centers
___-IN	Institutional Handle - Tamper-Proof and Vandal-Resistant
___-P	1-1/4" [32mm] Pop-up Drain
___-PT	1-1/4" [32mm] Cast Brass P-Trap with a 7-1/2" [191mm] Long 17-Gauge Wall Bend
___-RKR	ADA Compliant Rocker Handle
___-140	140° Restricted Swing Spout
___-3F	0.5 GPM [1.9 L] Vandal-Resistant Pressure Compensating Female Spray Outlet
___-16F	1.0 GPM [3.8L] Vandal-Resistant Pressure Compensating Female Spray Outlet
___-21F	1.0 GPM [3.8L] Pressure Compensating Female Laminar Flow Outlet
___-22F	1.0 GPM [3.8L] Vandal-Resistant Pressure Compensating Female Laminar Flow Outlet
___-24F	0.35 GPM [1.3 L] Pressure Compensating Female Spray Outlet
___-25F	0.35 GPM [1.3 L] Vandal-Resistant Pressure Compensating Female Spray Outlet

ZURN INDUSTRIES, LLC ♦ COMMERCIAL BRASS OPERATION ♦ 2640 SOUTH WORK STREET ♦ FALCONER NY 14733

Phone: 1-800-997-3876 ♦ Fax: 1-919-775-3541 ♦ www.zurn.com

In Canada: ZURN INDUSTRIES LIMITED ♦ 3544 Nashua Drive ♦ Mississauga, Ontario L4V1L2 ♦ Phone: 905/405-8272 Fax: 905/405-1292