

MIFAB FLOOR DRAIN FEATURES

F1000 FLOOR DRAIN WITH HEAVY DUTY ROUND STAINLESS STEEL STRAINER

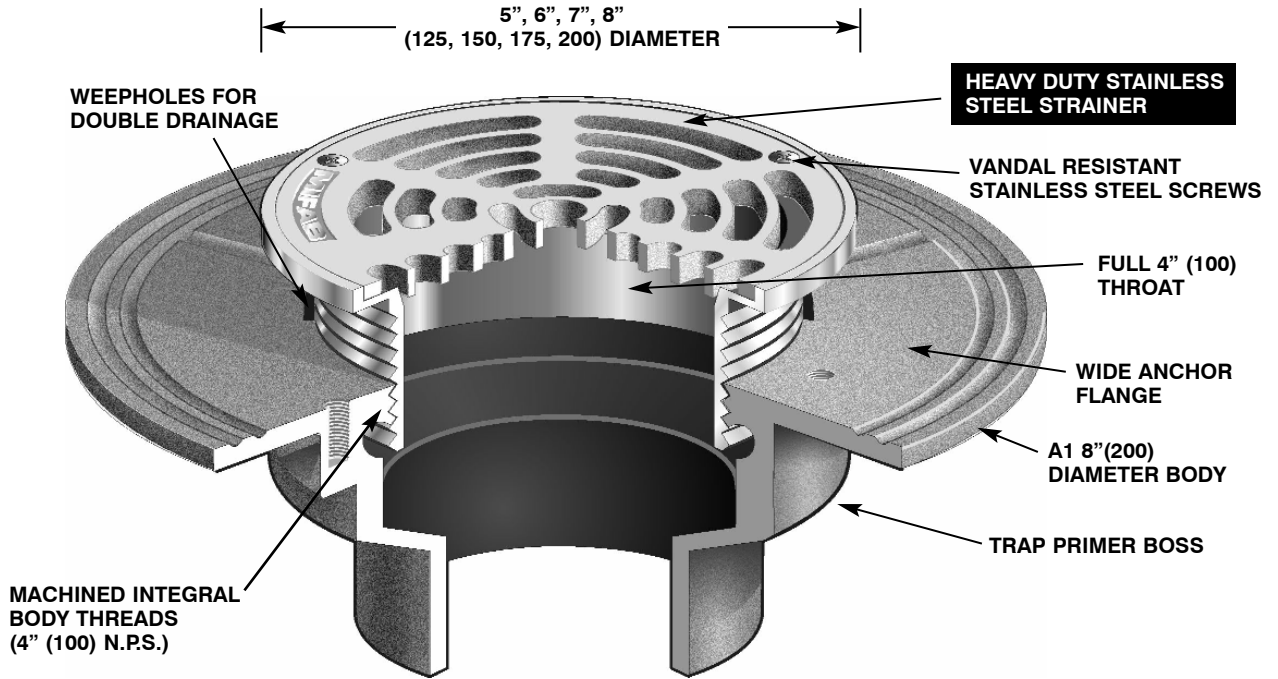

F1000-S FLOOR DRAIN WITH HEAVY DUTY SQUARE STAINLESS STEEL STRAINER

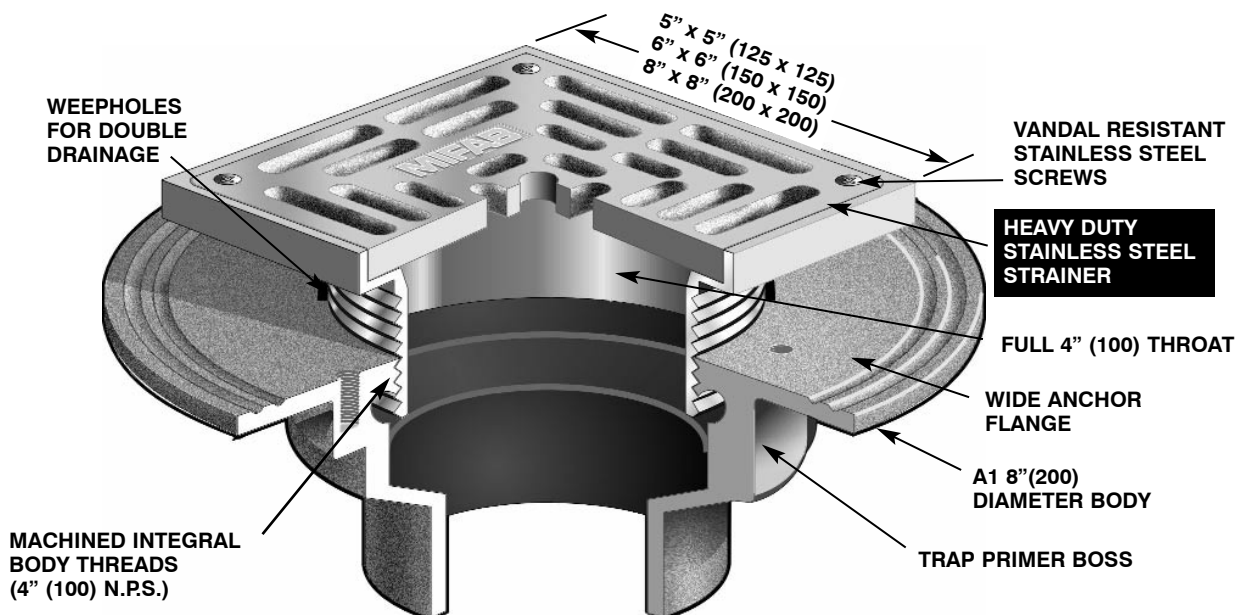

MIFAB AREA DRAIN FEATURES

F1340 FLOOR DRAIN WITH 12" ROUND ADJUSTABLE TRACTOR GRATE

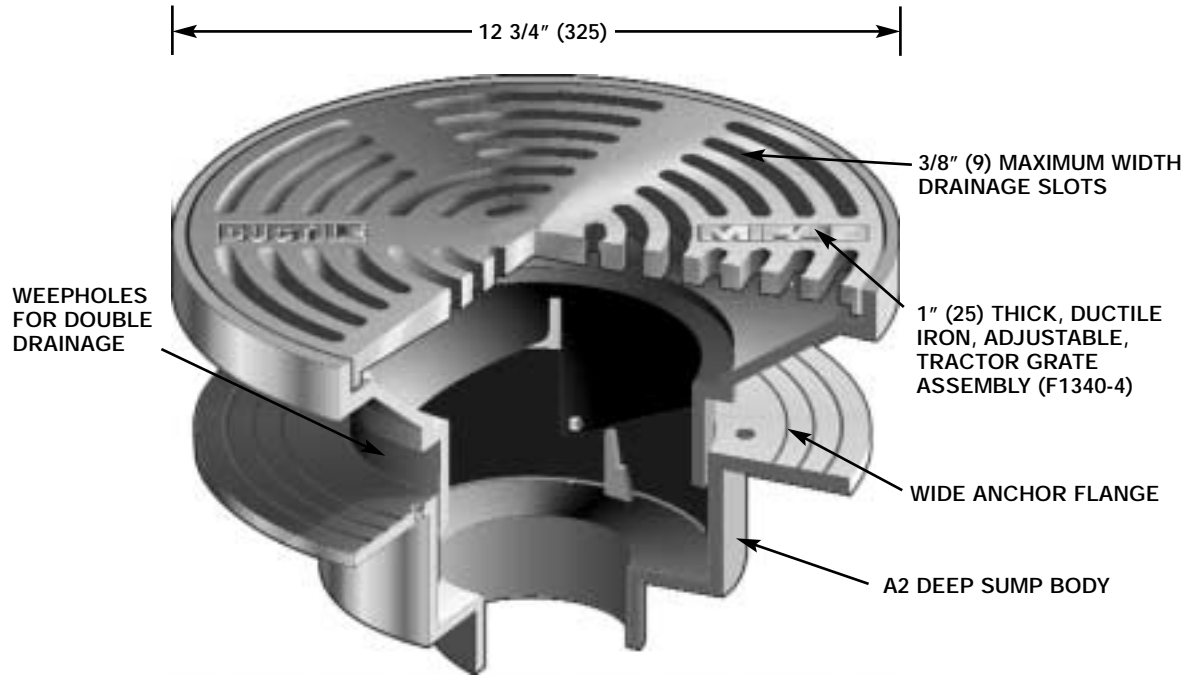

F1440 FLOOR DRAIN WITH 12" SQUARE ADJUSTABLE TRACTOR GRATE

