

Location: \_\_\_\_\_



**F1170-C**

**FLOOR DRAIN WITH MULTI INLETS AND INTEGRAL TRAP FOR MEMBRANE FLOOR AREAS**

**Specification:** MIFAB Series F1170-C lacquered cast iron floor drain with integral trap, 2" (51) cleanout (rodding eye), anchor flange, cast iron membrane clamp ring with primary and secondary weepholes for waterproofing membrane, and standard reinforced, (specify diameter), (specify material finish) strainer. (Specify -44 2" (51) no hub side inlet. Maximum three @ 90 degrees. Specify location -A, B, or C.)

**Function:** Used in toilets, kitchens and other membrane finished areas where additional inlets are required to receive drainage. Integral deep seal trap prevents sewer gas from entering area.

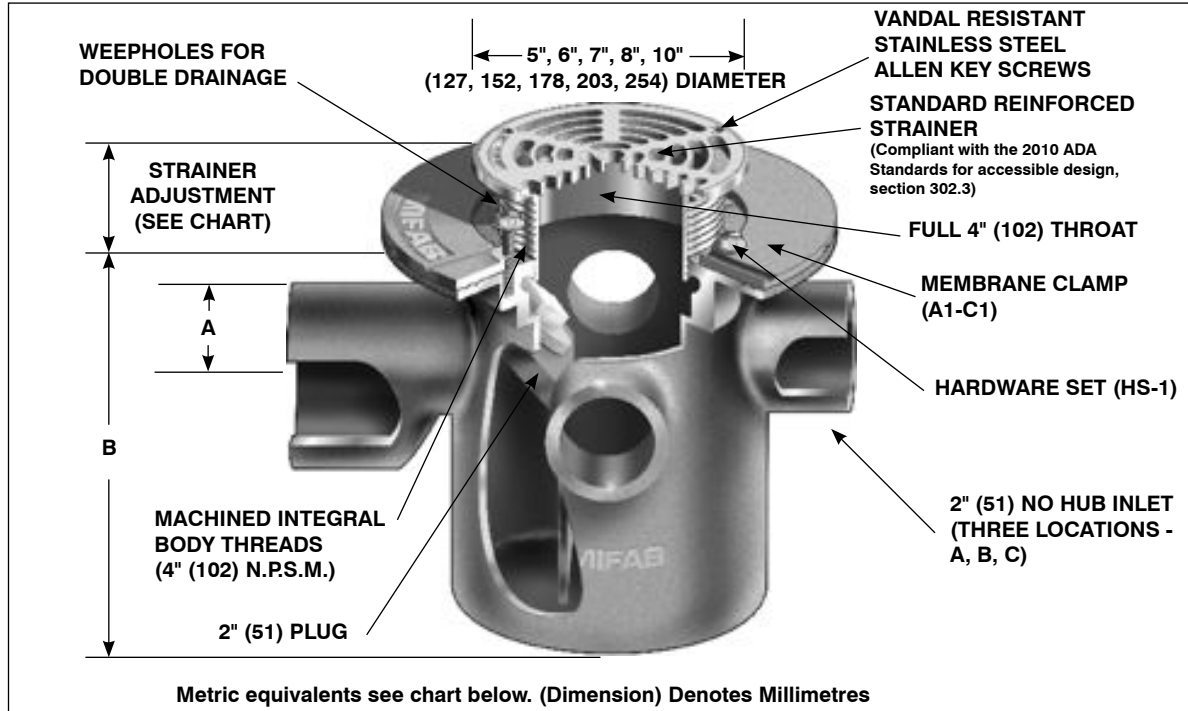

**PARTS:**

F1170-C (\*)

(\*) Denotes Outlet Size

A1-C1

HS-1

(\*)-(\*\*)

(\*) Denotes Strainer Diameter (5", 6", 7", 8" or 10")

(\*\*) Denotes Strainer Finish (-1, -3 or -4)

STRAINER DIAMETER	STRAINER ADJUSTMENT		ANSI/ASME RATING				PIPE SIZE	BODY HEIGHT	
			FREE AREA	LOAD RATING				A	B
	MIN	MAX		N.B. (-1)	S.S. (-3)	D.I. (-4)			
5" (127)	1 9/16" (41)	2 11/16" (68)	8 in <sup>2</sup> (5200 <sup>2</sup> )	UP TO 2,000 LBS.	5000-7499 LBS.	UP TO 7,499 LBS.	3" (76) 4" (102)	3 3/4" (95)	7 7/8" (200)
6" (152)	1 11/16" (43)	2 5/8" (67)	9 in <sup>2</sup> (5800 <sup>2</sup> )	UP TO 2,000 LBS.	5000-7499 LBS.	--			
7" (178)	1 1/2" (38)	2 5/8" (67)	12 in <sup>2</sup> (7700 <sup>2</sup> )	UP TO 2,000 LBS.	5000-7499 LBS.	--			
8" (203)	1 7/8" (48)	2 3/4" (70)	18 in <sup>2</sup> (11600 <sup>2</sup> )	UP TO 2,000 LBS.	5000-7499 LBS.	UP TO 10000 LBS.			
10" (254)	1 1/16" (17)	2 1/4" (57)	26 in <sup>2</sup> (17170 <sup>2</sup> )	--	5000-7499 LBS.	--			

F1170-C Series meets ANSI-ASME floor drain standard A112.6.3-2001

**SUFFIX OPTIONAL VARIATIONS**

- 1 Nickel bronze strainer
- 3 Stainless steel strainer
- 4 Ductile iron grate (5" x 8" only)
- 5 Sediment bucket
- 6 Security screws (T-20 Torx & pin)
- 7 1/2" trap seal primer connection
- 8 Backwater valve (2", 3", 4")
- 11 Acid resistant epoxy coated body
- 13 Galvanized body
- 15 Extension

**SUFFIX OPTIONAL VARIATIONS**

- 34 Closure plug
- 44 2" (51) no hub inlet (specify A, B, C locations)
- 49 Chrome Plated Strainer
- 50 Lacquered cast iron funnel
- 95 Client logo
- ARRA ARRA (Stimulus Act) compliant product
- BA Buy American Act compliant product

**SUFFIX OPTIONAL VARIATIONS**

- C2 High rough-in membrane clamp (min. 1 9/16" (40))
- F4 4" Round funnel
- F6 6" Round funnel
- G Oval 4" x 9" funnel
- HP Heel proof grate (1/4" maximum grate opening size, -3 only)
- J 6" x 3" x 1" funnel
- PA Pennsylvania Steel Act compliant product
- Z Extended wide elastomeric flange

Job Name: \_\_\_\_\_  
 Section No: \_\_\_\_\_  
 Schedule No: \_\_\_\_\_

Page No: \_\_\_\_\_  
 Contract: \_\_\_\_\_  
 Purchase Order No: \_\_\_\_\_