

Location: _____



F1570

24" x 24" HEAVY DUTY PARKING AREA CATCH BASIN

Specification: MIFAB Series F1570 - (A, B, C, D or E) powder epoxy coated heavy duty parking area catch basin with anchor flange, and extra heavy duty 24" x 24" (610 x 610) two section (specify material finish) grates with a free area of 200 square inches (129,032²). Grates to have maximum 13/16" (21) openings.

Function: Used in industrial factories, mechanical rooms, parking garages and other membrane finished areas. 24" x 24" tractor grate is used with all types of poured finished floors. The anchor flange provides maximum support for drain. Extra deep sump body is designed to handle large flows of water.

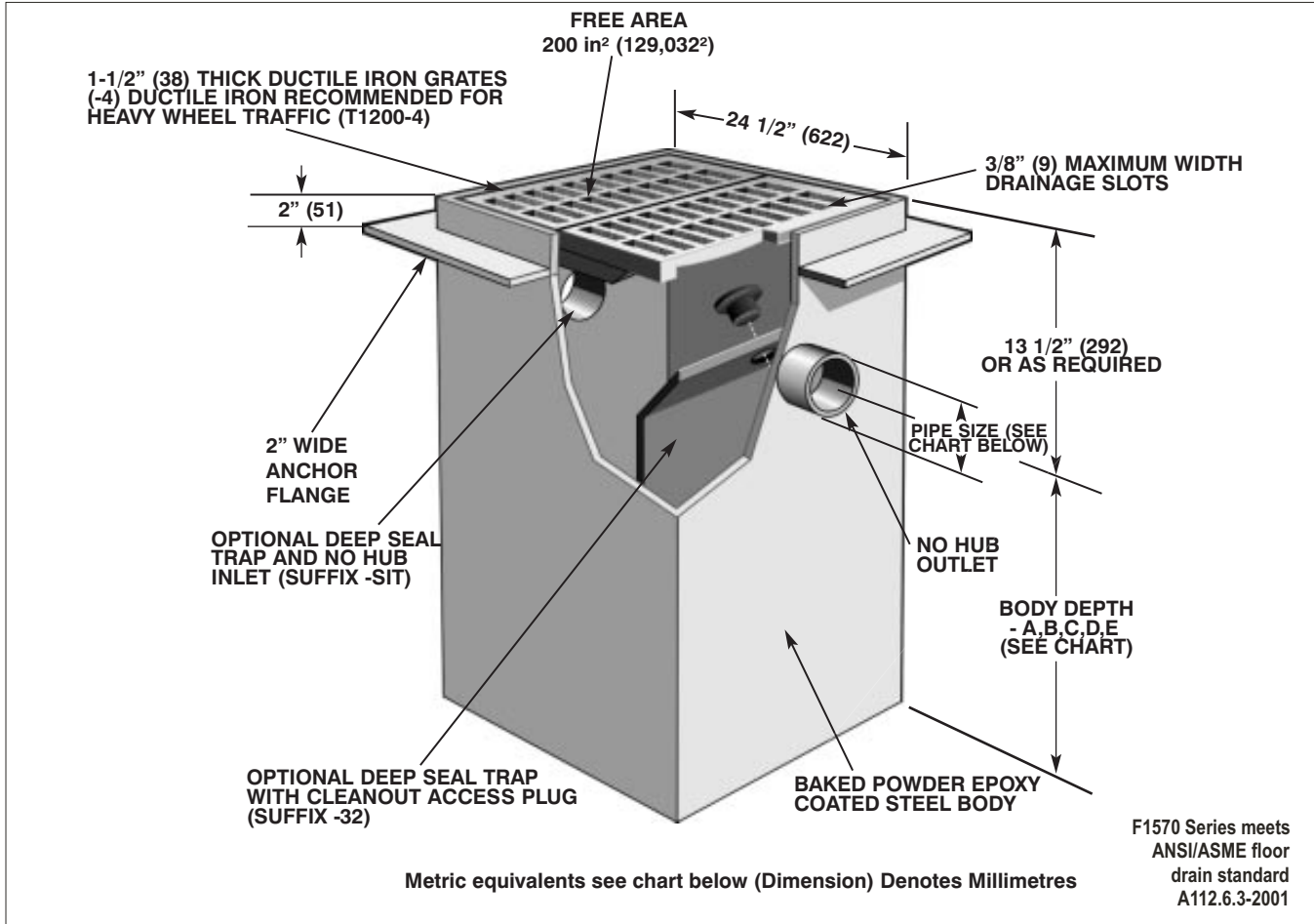

MODEL NO.	NO HUB PIPE SIZE	BODY DEPTH	
F1570-A	2" (51)	18" (457)	
F1570-B	3" (76)	24" (610)	
F1570-C	4" (102)	30" (762)	
F1570-D	6" (152)	36" (914)	
F1570-E		SPECIAL	

SUFFIX OPTIONAL VARIATIONS:

- 3 Stainless steel veneer grates
- 4 Ductile iron grates
- 6 Security screws (TR30 Torx & pin)
- 12 Galvanized grates
- 13 Galvanized body
- 15 Extension
- 28 Stainless steel body (Type 304)
- 32 Deep seal trap on outlet side
- 95 Client logo

SUFFIX

- ARRA ARRA (Stimulus Act) compliant product
- BA Buy American Act compliant product
- C Membrane clamp
- SI No hub side inlet
- SIT No hub side inlet trap
- PA Pennsylvania Steel Act compliant product
- (Specify) Special outlet size

Job Name: _____ Page No: _____
 Section No: _____ Contractor: _____
 Schedule No: _____ Purchase Order No: _____

MIFAB reserves the right to make changes in material and design without formal notice and obligation.